

PCB Delamination

A Precision Material Removal System™

WHAT IS THE PRECISION MATERIAL REMOVAL SYSTEM™ (PMRS)?

The PMRS is a package of processes & equipment designed to effectively and quickly delaminate multilayer PCBs and also remove conformal coatings in preparation for imaging on the ScanFAB™ system. The PMRS is a tool designed to complement ScanCAD's diverse family of Reverse Engineering products.

MICRO-ABRASIVE BLASTING

One of the most effective and safest methods to remove the substrate material from a multi-layer printed circuit board is micro-abrasive blasting or 'MicroBlasting'. With micro-abrasive blasting, the task of removing the substrate material is fast, safe, environmentally friendly, and cost-effective. It supports careful control over the process to eliminate damage to delicate features, such as small traces/pads. Many kinds of substrate material such as FR4, Polyamide, Rogers and Thurmont can be easily and quickly removed. Using the PMRS for PCB Delamination application does not require highly trained personnel when using ScanCAD's step by step procedures and training videos.

THE PROCESS

The process includes clear step-by-step guidance on how to use our complete, self-contained, delamination system combined with a variety of accessories and the proper abrasive powder and nozzles to provide excellent PCB delamination & conformal coating removal results on a wide variety of substrate materials and conformal coatings. The process has been carefully tested and proven to work, eliminating guess work and costly mistakes.

WHY USE THE PMRS TOOL?

This process is powerful and accurate and reduces the risk of damage to components, connections, and PCB features such as external and internal copper layers with fine traces & spaces. Workflows, videos and documentation are included for training purposes.

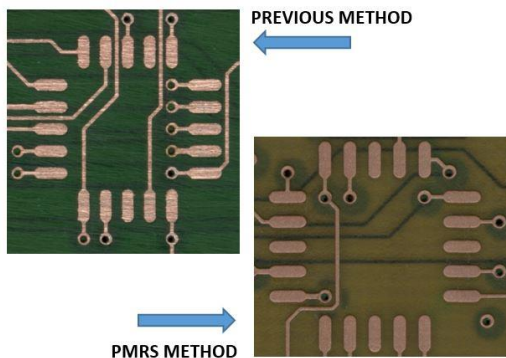

SYSTEM INCLUDES:

ScanCAD's proprietary knowledge, supplies, machine settings information (including nozzle types & process recipes), and training materials required for either the **PCB Delamination application** or the **Conformal Coating Removal application**.



BENEFITS OF THE PMRS TOOL

- **Accurate:** Process the smallest trace & spaces safely
- **Fast:** Much faster than previous techniques
- **Flexible:** Multipurpose – PCBs, Components, etc.
- **Eliminate:** Mess & contamination concerns
- **Easy:** Simple step by step procedure
- **Safe:** Advanced HEPA filter built into the unit
- **Versatile:** Can be also be used for multiple applications, such as:
 - Conformal Coating Removal**
 - Small part Deburring**
 - Polishing & Cleaning**

ABRASIVE MEDIA

The type of abrasive powder used has the most significant impact on the tool's effectiveness. The size, hardness and shape of the individual particles give each type of powder unique characteristics.

Substrate Types:

FR4 Polyamide Rogers Thurmont

THE RIGHT MIX

With each new application, the factors below are tested with nozzle and powder selections. The formula that works best will be determined by:

1. Type of conformal coating to be removed
2. Thickness of the coating
3. Type of base product the coating is covering.

Once the correct combination is achieved, keeping these parameters constant is easy – producing repeatable and consistent results.

MEDIA DISPENSING SUBSYSTEM

Adjustable pressure settings for accurate mixing and delivery of media and air along with precision nozzles for precise delivery of media are required for the precision PCB Delamination application. Easy access, easy to fill media chamber coupled with an adjustable high precision media and air regulator.

Electro Static Discharge (ESD) Control PMRS Model is used for the Conformal Coating Removal application.

The ESD Model combines the standard PMRS workstation, dust collector, and the ESD controls into a single compact unit.

Military, consumer and industrial applications alike often involve devices that are sensitive to and can be damaged by exposure to **Electro-Static Discharge (ESD)**. An Ionizer bar with a series of electrode probes that continuously emit a flow of charged ions into an air stream flowing out from around each of the nozzles. This flow of highly ionized air floods the system's work area and quickly neutralizes any surface charges.

To further reduce the build-up of ESD, the system includes the following accessories: edge-connector grounding bar, needle probe, grounded hand piece and conductive nozzles.

The **Patented** modulator feed system, provides a very consistent stream of abrasive material from the nozzle. This is critical because any variation in abrasive flow will impact how deep the process cuts. Modulated feed is an ideal for this challenge.

The **special gate valve** on the media dispensing unit produces a fast response when starting and stopping the abrasive flow. This design improves the longevity and durability of the systems and avoids having to pinch the abrasive hose which causes wear, or to use a sacrificial tube, which will wear very quickly.

Black Lights

Black lights come in as standard tools for the ESD Control PMRS Model. Designed for those coatings that are easily visible under ultra-violet lighting.

ADDITIONAL MICROBLASTING USES WITH THE PMRS TOOL

1. Conformal Coating Removal

The PMRS can also be used during the PCB Reverse Engineering process to delaminate Printed Circuit Boards.



2. Small Part Deburring

The PMRS Tool is a perfect tool to carefully remove burrs from small and intricate parts.



Gears

Manifolds

COMPLEMENTARY TOOLS

• Magnifier (Optional)

See small details easily and reduce eye strain with a 2.5X magnifier. With an 8-10" depth of focus, the operator can work at a normal, natural distance.



TECHNICAL SPECIFICATIONS

The PMRS SYSTEM comes in 2 Models:

1. Standard Model
2. ESD Control Model

Specifications:

- Advanced downdraft HEPA filter - 500 SCFM
- 99.97% filtration efficiency on 0.3 micron-sized particles
- Ergonomic design reduces operator fatigue
- Size/weight: 30"Wx46"Hx34"D / 170 lbs (77.3 Kgs)
- Interior space: 2.2 ft.³ 24" wide X 14" deep X 10" high (approx.)
- Window: Tempered glass opening (hinged) 23"X11"
- Lighting: 18-Watt black fluorescent lights (2)
- Sound level: 68 dBA
- CE & RoHS Compliant
- Requirements:
 - 115V/60Hz 4 amp or 230V/50Hz 2 amp
 - 80 psi air supply of 4 SCFM required

PMRS System includes:

- Integrated Hardware & Accessories
- Proper abrasive powder & nozzles for PCB's
- Standard supplies included
- ScanCAD training materials – videos, workflows

ESD Control Model includes:

- Black Lights
- Edge-connector grounding bar
- Needle probe
- Grounded hand piece and conductive nozzles
- Grounding jacks inside the blast chamber
- Ionizer bar
- **Patented** modulator feed system.

(All specifications and designs subject to change without notice.)
Rev 18012920

26437 Conifer Rd.
Conifer, CO 80433 USA
T: +1 303.697.8888 F: +1 303.697.8580
E: info@scancad.com www.scancad.com

